

MECHANICAL CYCLE COUNTER

RABOURDIN launches a new range of product for the injection mold ; cycle counters to indicate mould activity, to validate process monitoring data, and to assist mould maintenance procedures.

THE CYCLE COUNTER
HAS A WARRANTY FOR
THE ALL MOULD LIFE





REF. 409-1

SPECIFICATIONS

- Maximum operating temperature is 120°C
- Non-resettable mechanical counter, with 7-digit display
- Glass-filled Nylon housing
- Socket for M4X25 screws
- Security ID Plate GR
(with mould information, serial number)
- Compact counter that can be mounted internally or externally
- Machined with a single tool

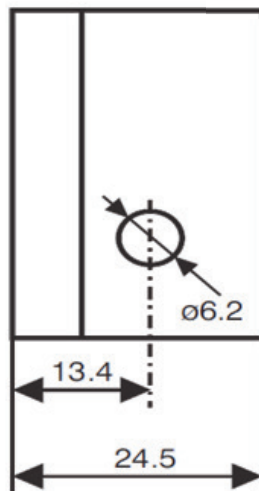
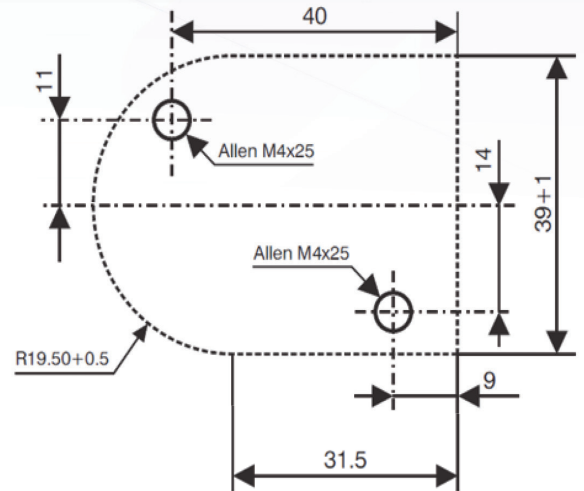
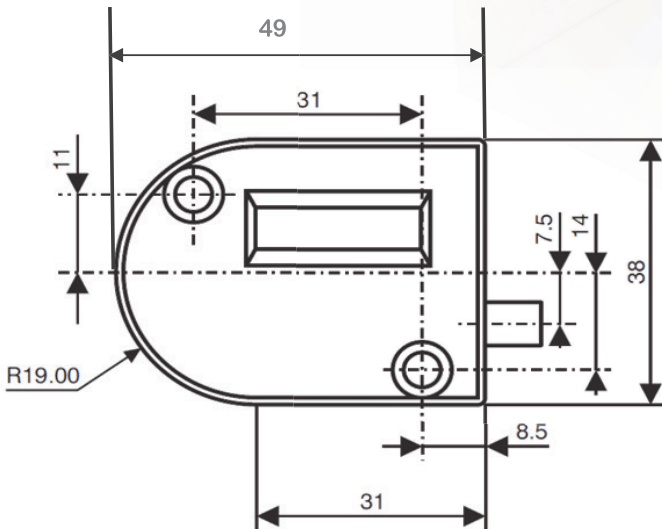
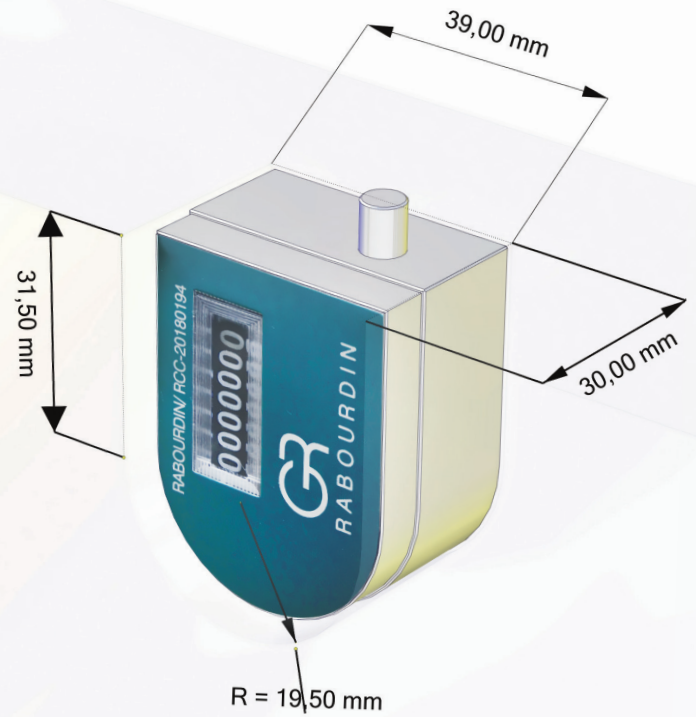

PRECAUTION FOR USE

- Do not press the push button with the finger or any other strong object to avoid any damage
- Do not test the cycle counter on a press or machine without any cut out done earlier

WWW.RABOURDIN.FR